

SPACE DIVIDER







INTACT 3000, a Belgian-based company ideally located in the heart of Europe, designs, develops and manufactures its own movable or relocatable partitioning system which is used throughout the world.

The elegant and smart design of INTACT partitions offers a total aesthetic freedom and endless possibilities to the space designer. Its unique concept based on compatible profiles matching the original structure ensures the technical integrity of the system in its most exclusive versions. The strict control of raw material supply, in accordance with most demanding international standards, guarantees the quality of the final product in its most audacious applications. INTACT partitioning system provides to the designer a unique base for permanent innovation in space dividing solution with the insurance of technically sound characteristics. Whether for commercial, administrative, industrial work places or airport, schools or showrooms, its applications are infinite.

In terms of services, INTACT 3000 provides the full sequence from project design, quantities calculation, supply of all components transportation to site included.

INTACT 3000 exports overseas over 60% of its production through a wide network of distribution. Main markets are EEC, Switzerland, India, Gulf countries, Algeria, Sudan, and Republic of Congo. With a branch and manufacturing facilities established in 2006 in Sharjah, U.A.E, and a subsidiary named Intact Interior Pvt Ltd established in 2008 in Bangalore, India, INTACT 3000 is definitely the global partner to expand into the 21st century.

The CRYSTAL SG partition is a combination of glass and glass support without internal structure. The profiles are minimized to protect the clarity and transparency of the partition. The system is designed to be fully demountable and relocatable.



CRYSTAL SG - LIGHT, SPACE, TRANSPARENCY



TECHNICAL DATA

Dimensions

Profile set section: 38 mm x 38 mm

Glass thickness: 10 mm or 12 mm

Height: 3000 mm (maxi)

Module width: 1000~1200 mm (recommended)

Materials

Tracks: aluminium mill finish with cap anodized or RAL painted

Glass: tempered or laminated

Glass connection, plastic material

Tsection & corner:

Door shutter: any size, solid core 40mm, aluframed glass or frameless tempered glass

Door system: hinges or sliding or spring pivot

SINGLE GLAZED: CRYSTAL SG PARTITION





CRYSTAL DG partition is a glazing system fully integrated in the 95 (SL, P or F) INTACT partition. The flush system provides a continuous clarity without visible structure. Transparent structural fins achieved high resistance to flexion.



CRYSTAL DG PARTITION



TECHNICAL DATA

Dimensions

Thickness: from board to board 95 mm
widest profile 104 mm

Height: up to 3000 mm

Module width: currently 1000~1200 mm or lower

Materials

Structure: internal structure in galvanized steel; S-shaped studs

Profiles: visible profiles made out anodized or epoxy-coated aluminium

Glass: tempered or laminated 4 to 8 mm thick

Door leaves: HPL solid, tempered glass, aluframed glazed

Performances

Noise attenuation: 40 to 44dB depending glass type

Relocability and stability according to CERFF (France) test approval



INTACT DG: VARIATIONS

CRYSTAL DG PARTITION

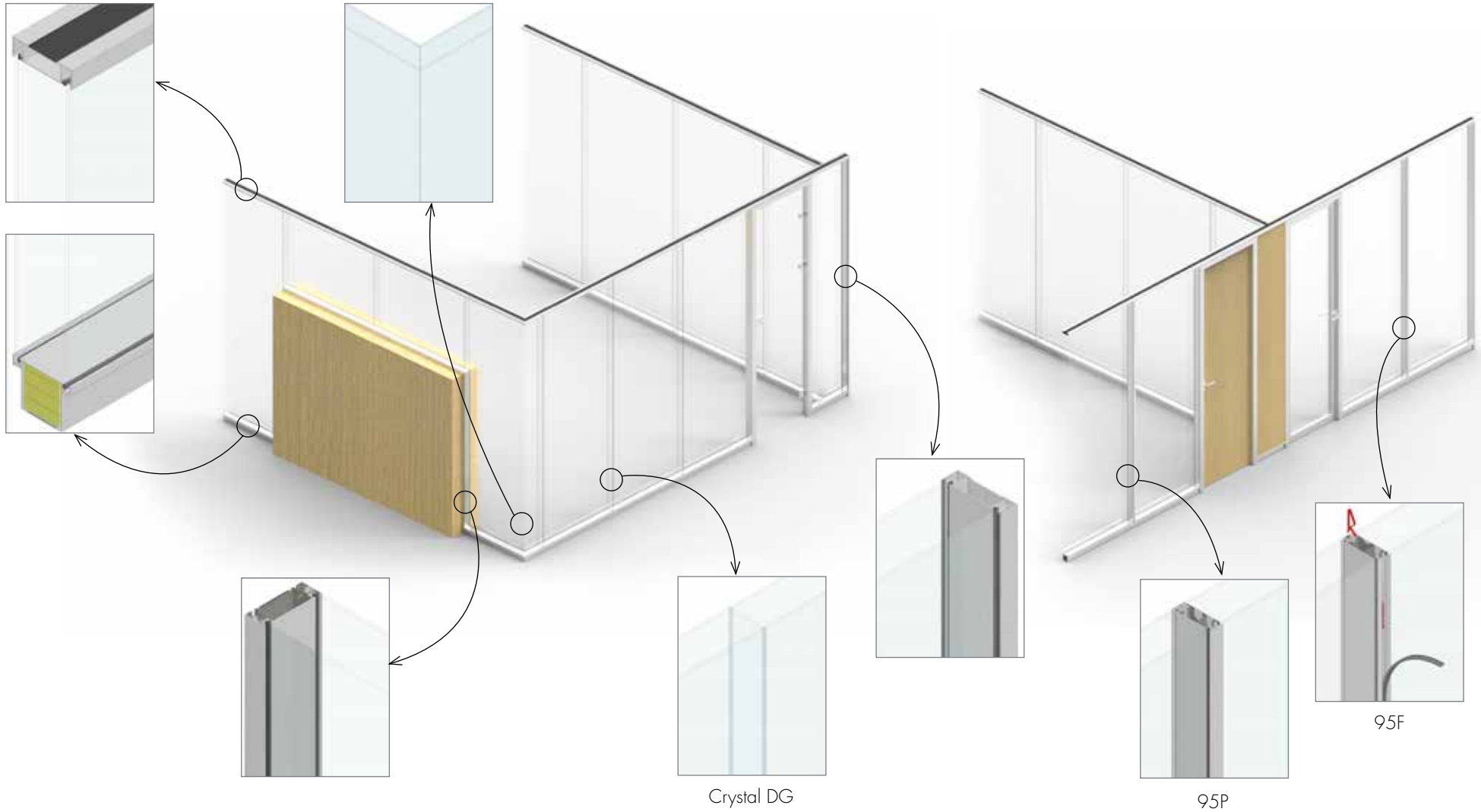

INTACT 95

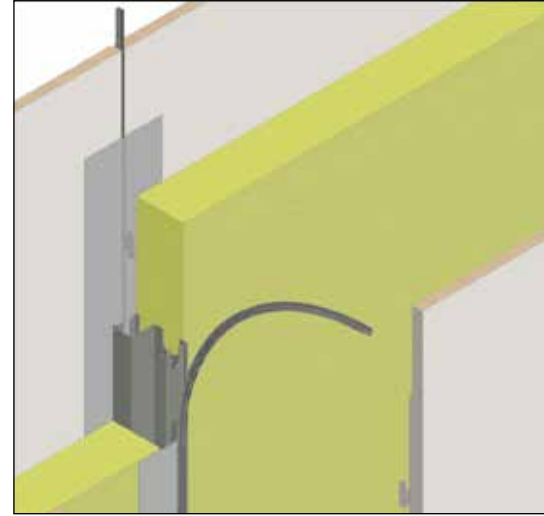
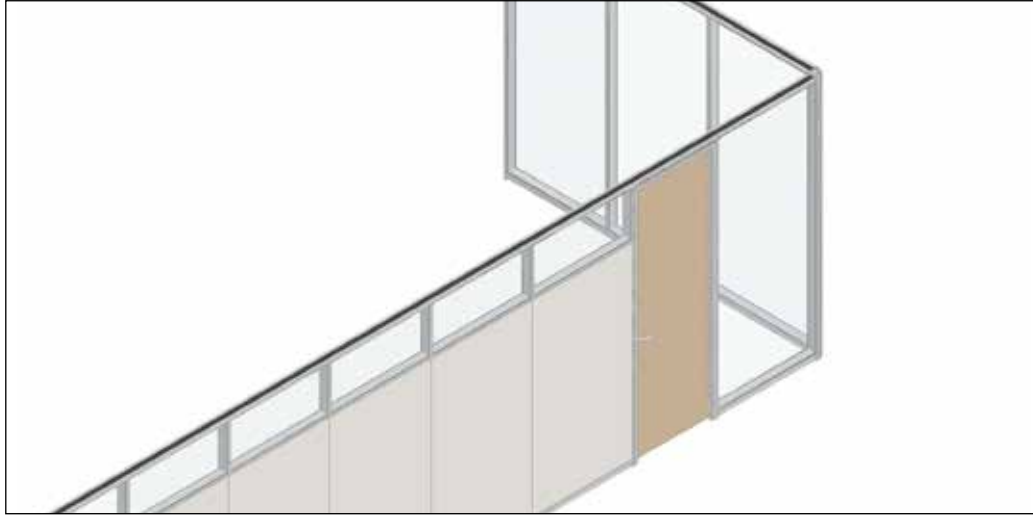

The gap between panels is pre-set at 3 mm. It can be extended. Panels will be on wood material. Long sides of panels require perfect finish: pvc for particle boards, clear cut for MDF.

INTACT 95SL

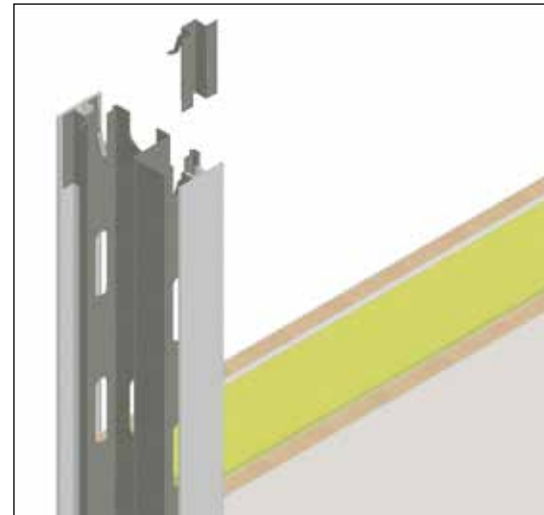
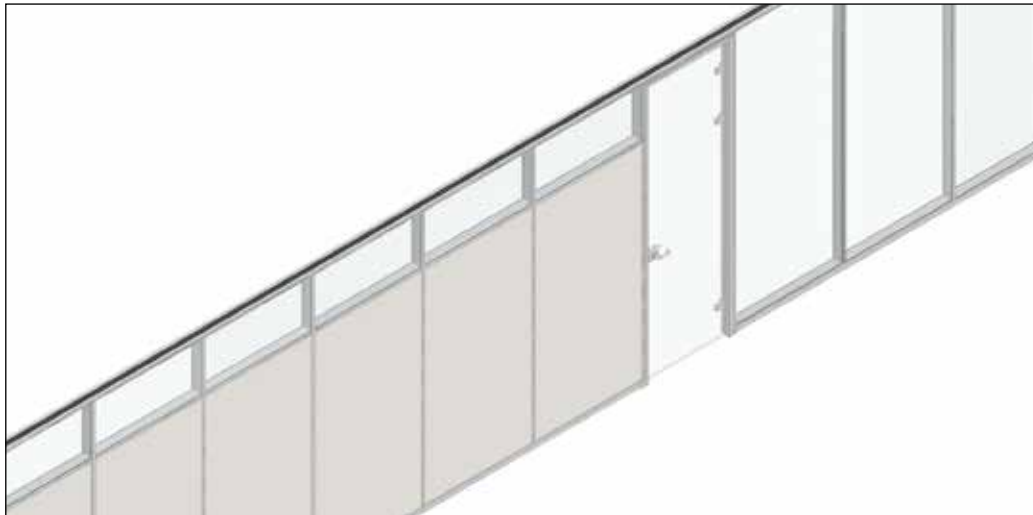

Solid Partition with flush and flat aluminium profile

INTACT 95P

INTACT 95

Solid Partition with flush
moulding aluminium profile
of omega-shape.
The clips are covered by
a pvc profiles of matching
colour.

INTACT 95F

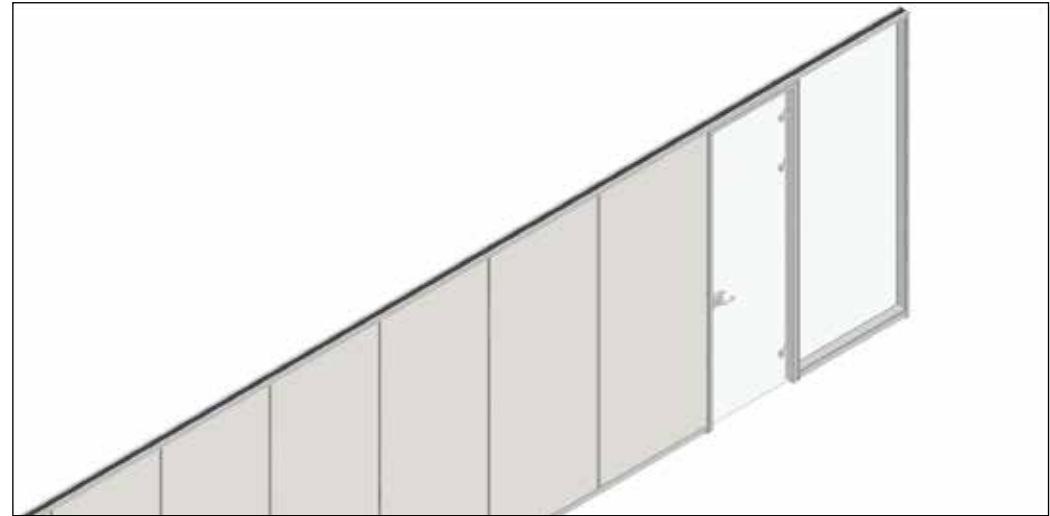
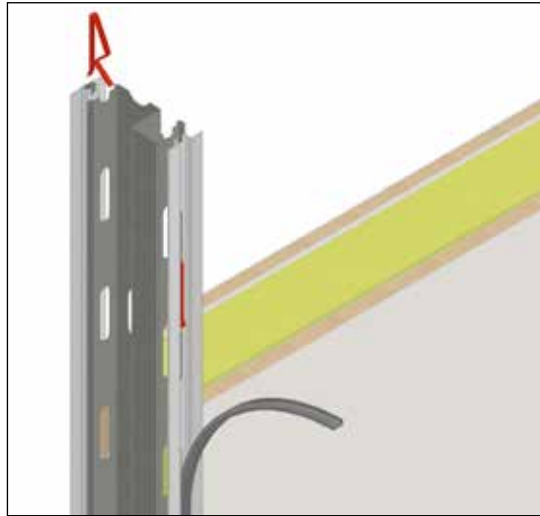

PARTITION WITH 12-14 MM PANELS VERSUS PARTITION WITH 18 MM PANEL.

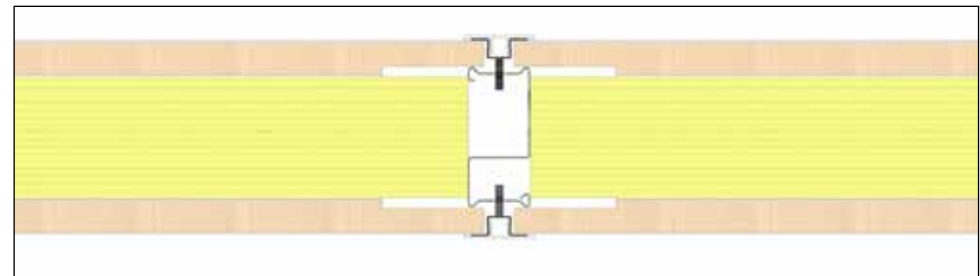
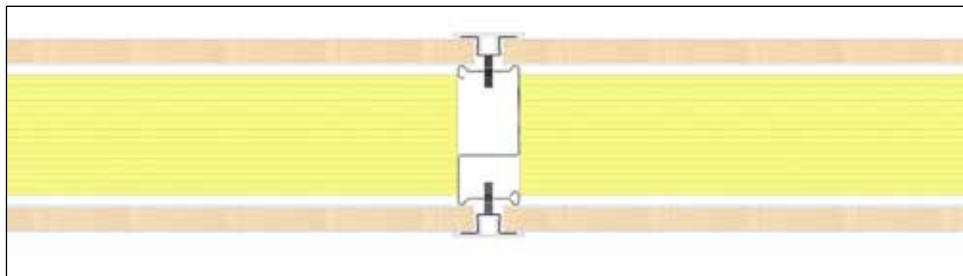

The shadow line system is the perfect answer to the current trend in design.
The gravity hung panels makes on-site construction and relocation easy.
Gap between panels, pre-set at 3mm may vary.



INTACT 95 SL - SHADOW LINE TYPE



TECHNICAL DATA	
Dimensions	
Thickness:	from board to board 95 mm; widest profile 104 mm
Height:	currently 2600 mm to 3000 mm; up to 3650 mm
Module width:	1200mm is the economic choice any lower value is possible
Materials	
Structure:	internal structure in galvanized steel; S-shaped studs
Profiles:	visible profiles made out anodized or epoxy-coated aluminium
Boards:	particle boards thickness 12-14 mm or 18 mm covered with melamine, HPL, wood, veneer, metallic sheets
Insulation:	60 mm thick high density rockwool with 12 mm board and 45 mm thick with 18 mm boards
Glass:	Float, tempered or laminated 4 to 8 mm thick
Door leaves:	HPL solid, tempered glass, aluframed glazed
Performances	
Noise attenuation:	solid with 12 mm boards:44dB Solid with 18 mm boards: 46dB
Relocability and stability:	according to CERFF (France) test approval
Inflammability:	all materials class MO & M1



Hunging panels has never been so easy

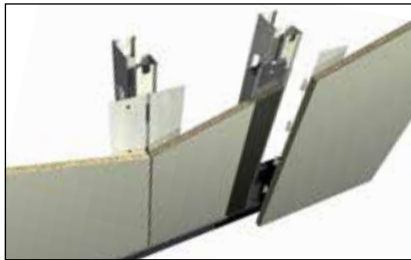

95 SL system requires clear cut of panels and edge pvc covering. Studs may be equipped with height adjustment device

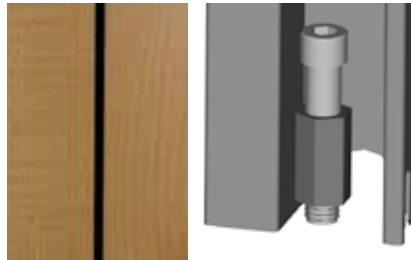



- Traditional flush omega system
- The perfect flexibility, re-usability and relocatability
- The ultimate partition in industrial application

INTACT 95 F

TECHNICAL DATA

Dimensions

Thickness:	from board to board 95 mm; widest profile 104 mm
Height:	currently 2600 mm to 3000 mm; up to 3650 mm
Module width:	1200mm is the economic choice any lower value is possible

Materials

Structure:	internal structure in galvanized steel; S-shaped studs
Profiles:	visible profiles made out anodized or epoxy-coated aluminium
Boards:	particles or gypsum boards thickness 12-14 mm or 18 mm covered with melamine, vinyl, HPL, wood veneer, steel sheets
Insulation:	60 mm thick high density rockwool with 12 mm board and 45 mm thick with 18 mm boards
Glass:	Float, tempered or laminated 4 to 8 mm thick
Door leaves:	HPL solid, tempered glass, aluframed glazed

Performances

Noise attenuation:	solid with 12 mm boards: 44dB solid with 18 mm boards: 46dB
Relocatability and stability according to CERFF (France) test approval	
Inflammability:	all materials class MO & M1

- Multipurpose concept matching various architectural concepts
- The straight way to creative and innovating partitioning
- Easy and quick to install

INTACT 95 P



TECHNICAL DATA

Dimensions

Thickness:	from board to board 95 mm; widest profile 104 mm
Height:	currently 2600 mm to 3000 mm; up to 3650 mm
Module width:	1200 mm is the economic choice any lower value is possible

Materials

Structure:	internal structure in galvanized steel; S-shaped studs
Profiles:	visible profiles made out anodized or epoxy-coated aluminium
Boards:	particles or gypsum boards thickness 12-14 mm or 18 mm covered with melamine, vinyl, HPL, wood veneer, steel sheets
Insulation:	60 mm thick high density rockwool with 12 mm bard and 45 mm thick with 18 mm boards
Glass:	Float, tempered or laminated 4 to 8 mm thick
Door leaves:	HPL solid, tempered glass, aluframed glazed

Performances

Noise attenuation:	solid with 12 mm boards: 44dB solid with 18 mm boards: 46dB
Relocatability and stability according to CERFF (France) test approval	
Inflammability:	all materials class MO & M1



INTACT 120 P/F - THE ULTIMATE SOLUTION FOR HIGH PARTITIONING

The INTACT 120 is specially designed for industrial hall, building entrance, airports... wherever the height of ceiling exceeds 4 m; with a maximum of 15 m. The exceptional strength and stability is achieved by a cluster arrangement of two S-studs for structure. The width of the partition is increased by 20 mm.

TECHNICAL DATA	
Dimensions	
Thickness:	from board to board 115 mm; widest profile 132 mm
Height:	up to 15 m
Module width:	1200 mm is the economic choice any lower value is possible

Materials	
Structure:	internal structure in galvanized steel; double S-shaped studs
Profiles:	visible profiles made out anodized or epoxy-coated aluminium
Insulation:	60mm thick high density rockwool with 12 mm bard and 45 mm thick with 18 mm boards

Materials	
Boards:	particles or gypsum boards thickness 12-14 mm or 18 mm covered with melamine, vinyl, HPL, wood veneer, steel sheets
Glass:	Float, tempered or laminated 4 to 8 mm thick
Door leaves:	HPL solid, tempered glass, aluframed glazed

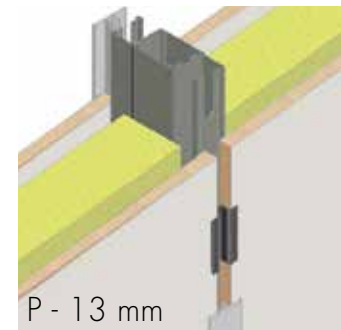
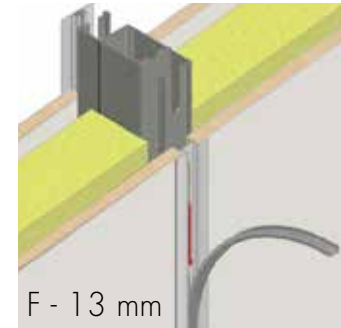

TEMPERED GLASS DOOR



IRONMONGERY



ALUMINIUM FRAMED GLAZED DOORS

STANDARD SIZE,
FULL HEIGHT &
HALF GLAZED



SLIDING DOOR & POWERED
SLIDING HALF
GLAZED DOOR

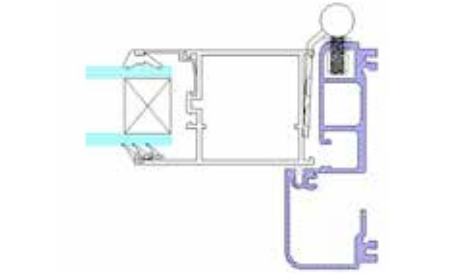

IRONMONGERY



WOODEN DOORS

STANDARD SIZE



SLIDING DOORS

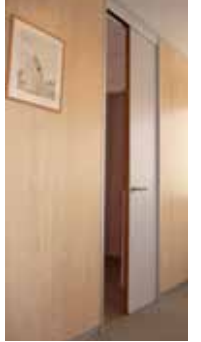

STANDARD
SIZE +
FIXED TOP



FULL
HEIGHT



IRONMONGERY





LIQUID CRYSTAL
SWITCHABLE FILM



WICKET



CUPBOARDS



ACCESSORIES



BLINDS



SWICHES



BOARD



PICTURE HANGING SYSTEMS



SCREENS





90° to 135° adjustable corner post



90° square corner post

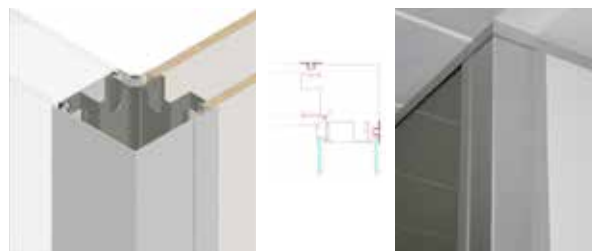

90° & 135° integrating discreet profiles

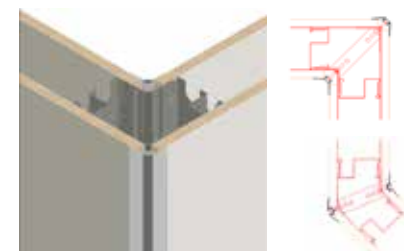

Clear glass corner



PROJECTS



BELGIUM

INTACT 3000 s.a.

Chaussée de Nivelles, 52

1461 ITTRE - BELGIUM

Tel +32 2 366 06 56

Fax +32 2 366 33 43

U.A.E.

INTACT 3000 - ME (Middle East)

PO BOX 42039, LOB 33, Office 33G-06

HAMRIYAH FREE ZONE, SHARJAH, U.A.E.

Tel +971 50 4558203

Fax +97165240982

INDIA

INTACT INTERIORS Pvt. Ltd.

#2, 7th Main 80Ft Road

Koramangala 1st block,

BANGALORE – 560034, INDIA

Tel +91 9663300094

Fax +91 80 41468558

info@intact3000.com
www.intact3000.com

